

10'x8' OVERLAP WORKSHOP ASSEMBLY

OLWS108FP

Should you require any additional guidance with the assembly of your workshop please contact our technical help line on 0844 248 9853 between the hours of 8:30am and 5:00pm Monday-Friday.

IMPORTANT, RETAIN FOR FUTURE REFERENCE: READ CAREFULLY

Thank you for choosing this garden building manufactured by the UK's largest manufacturer of timber garden products. In order to gain the most benefit from it, please note the following:

- Exercise particular care and follow instructions whilst cutting the roofing felt. If it is cut incorrectly, additional roofing felt can be inexpensively purchased from most good DIY retailers or garden centres.
- This product is pressure treated to ensure the longevity of all timber components and protect against rot. This may leave a colour difference in some parts that will even out as the moisture content stabilizes.
- If there are any technical queries with the product, please contact our customer help line on 0844 248 9853 between the hours of 8.30 am and 5.00 pm Monday to Friday.
- In line with your statutory rights, please check all parts prior to assembly, as assembly of damaged parts may be deemed to be acceptance and this may affect the remedies you are entitled to. If the product is not constructed in accordance with the instructions, or is altered in anyway (e.g. painted), the manufacturer cannot be held liable for any resulting damage
- Timber is a natural material. It will shrink and swell as a result of varying moisture content.
- Please keep all plastic bags and small parts away from children in order to reduce the risk of suffocation.
- This product should not be placed directly on the ground. A sufficient level base is needed.
- The roof of this building is not a load bearing structure.

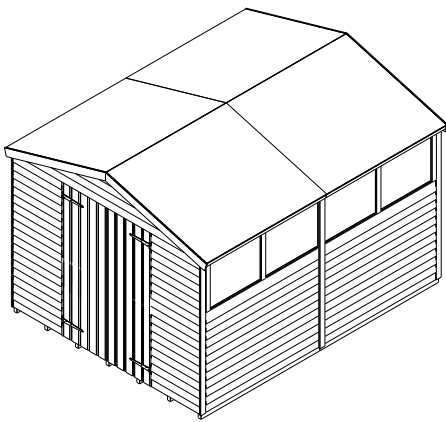

10'x8' Overlap Workshop



Important : Assembly of this workshop requires two people.

Helpful Tip : use the illustration of the screw/nail shown in each step to help you identify which fixing is required during the assembly of your workshop.

Required Tools : (Not Supplied)

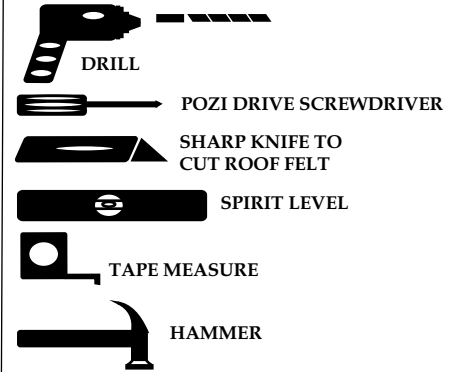

OLWS108FP (Fixing Pack) Contents :

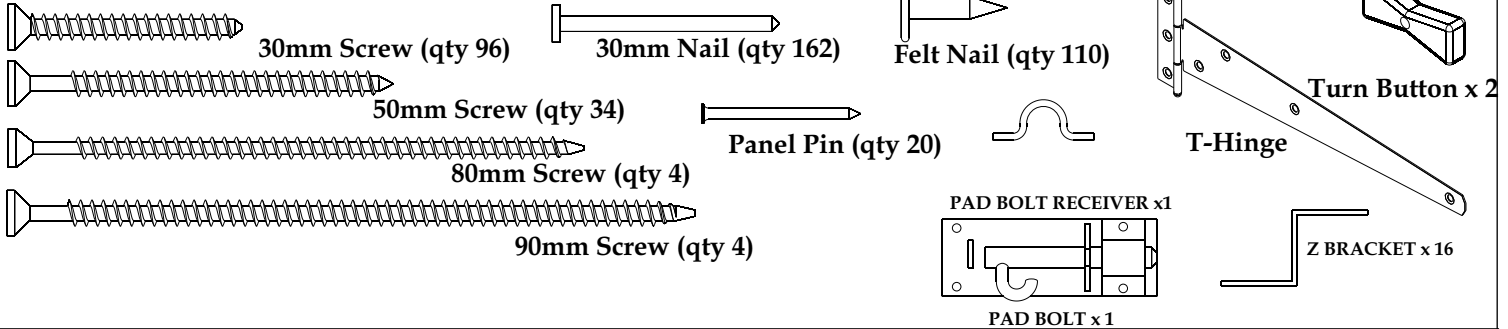

OLWS108LPTR (Loose Item Pack) -

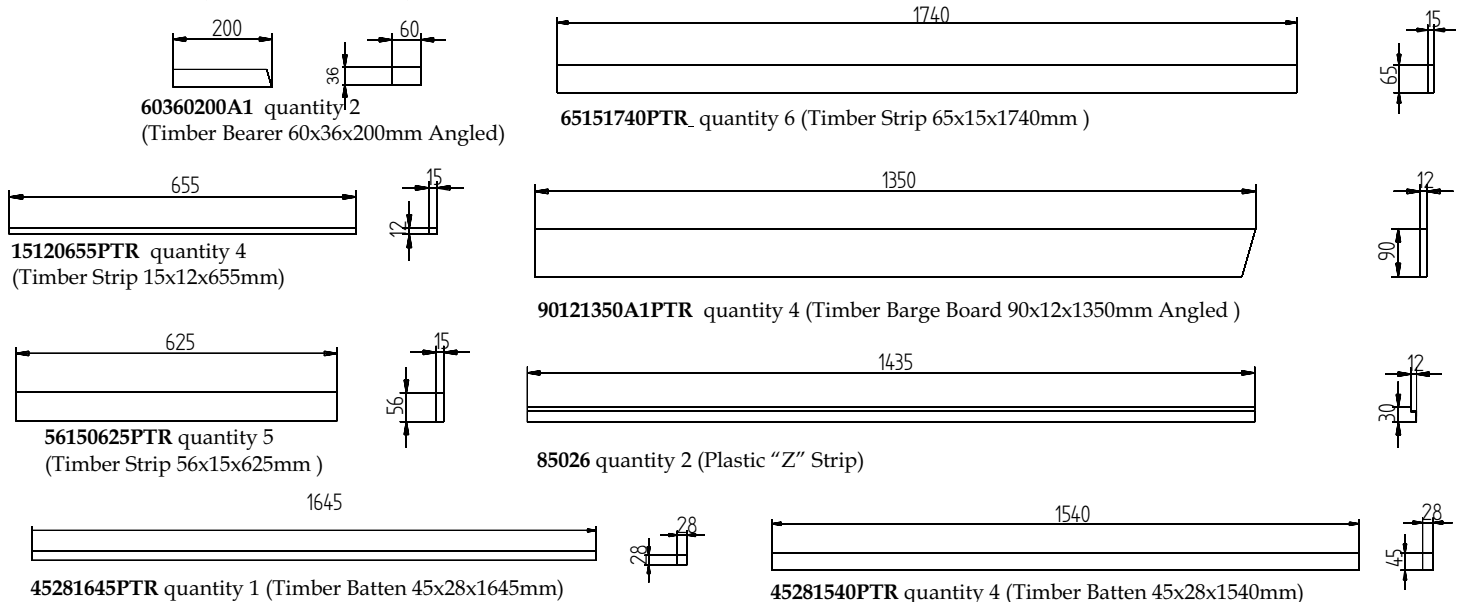

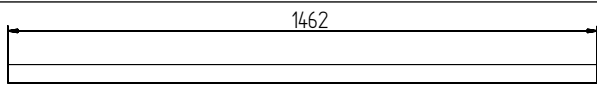

45281462PTR quantity 8 (Timber Batten 45x28x1462mm)

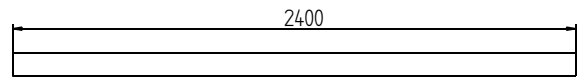

28282400PTR quantity 10 (Timber Batten 28x28x2400mm)



Components Included : Note: If you have a Pressure Treated workshop the alternative codes are in *Italics*

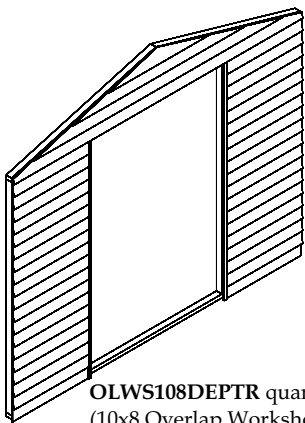

OLWS108DEPTR quantity 1
(10x8 Overlap Workshop Door End)

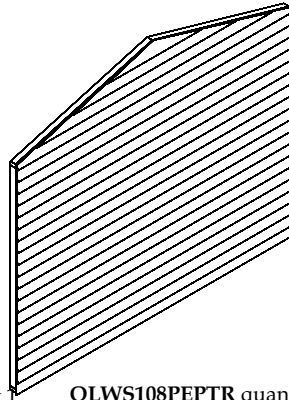

OLWS108PEPTR quantity 1
(10x8 Overlap Workshop Plain End)

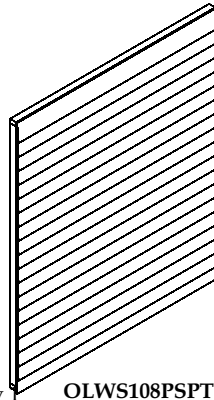

OLWS108PSPTR quantity 2
(10x8 Overlap Workshop Plain Side)

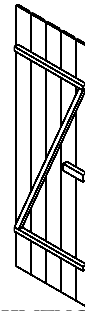

ADDHMTNGDRPTR quantity 2
(T&G Door 1715mm)



85008 quantity 3
(Green Mineral Felt)



OLWS108FP quantity 1
(10x8 Overlap Workshop Fixing Pack)

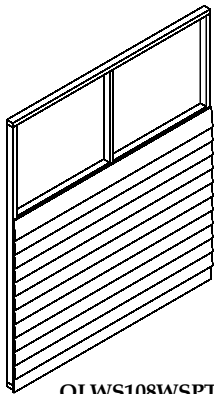

OLWS108WSPTR quantity 2
(10x8 Overlap Workshop Window Side)

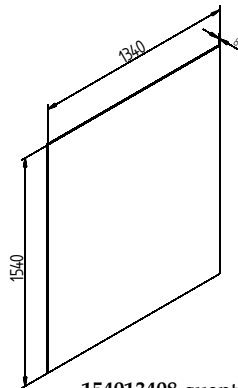

154013408 quantity 4
(OSB 1540x1340x8mm)

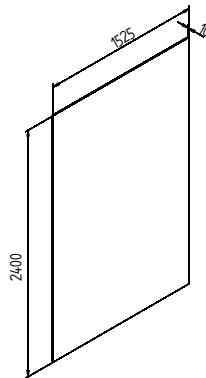

2400152510MFP quantity 2
(MFP 2400x1525x10mm)



OLWS108TRUSS quantity 1
(10x8 Overlap Workshop Truss)

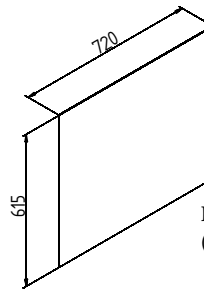

PW615720 quantity 4
(Styrene Window 615x720mm)

1

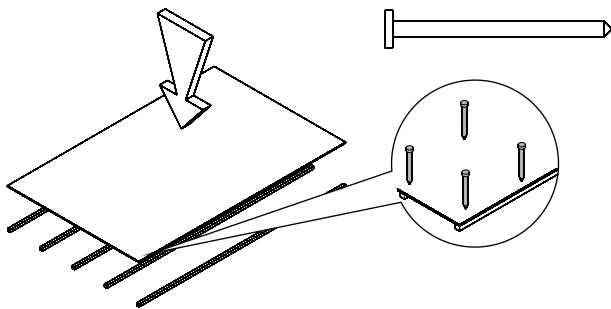

Place five 28282400PTR (batten 28x28x2400mm) on ground. Place one 2400152510MFP (MFP 2400x1525x10mm) on top of the battens. Ensuring that battens are evenly spaced, secure 2400152510MFP to each 28282400PTR with 30mm nails at 350mm intervals. Repeat procedure to make up second floor section.

2

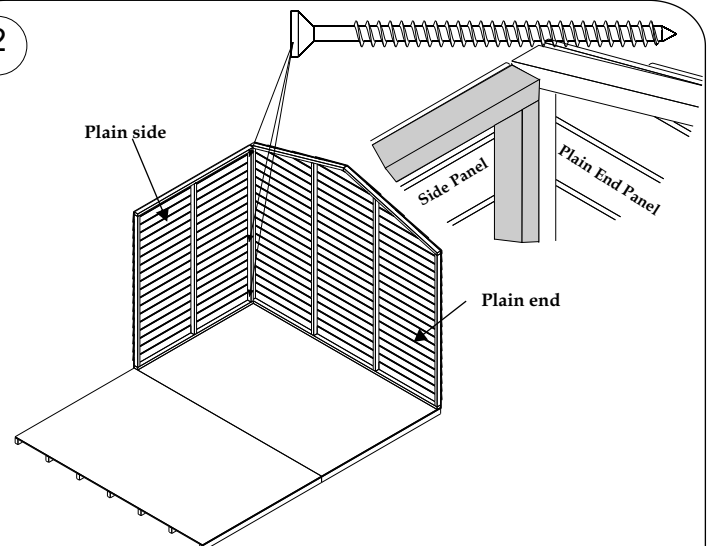

Position the two floor sections onto pre-prepared site. Floor bearers run from front to back of building. Place (plain end panel) onto floor section. Left and right hand edges of the panel must be flush with the left and right hand edges of the floor. Place one (plain side panel) onto floor so that it butts up against (plain end panel). Secure through framework of (plain side panel) into (plain end panel) with three 50mm screws as shown above. Do not secure panels to floor at this point.

3

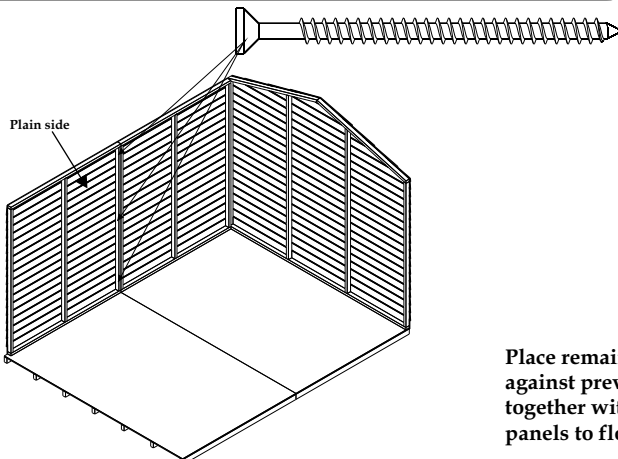

Place remaining (plain side panel) onto floor so that it butts up against previously positioned (plain side panel). Secure panels together with three 50mm screws placed as shown. Do not secure panels to floor at this point.

4

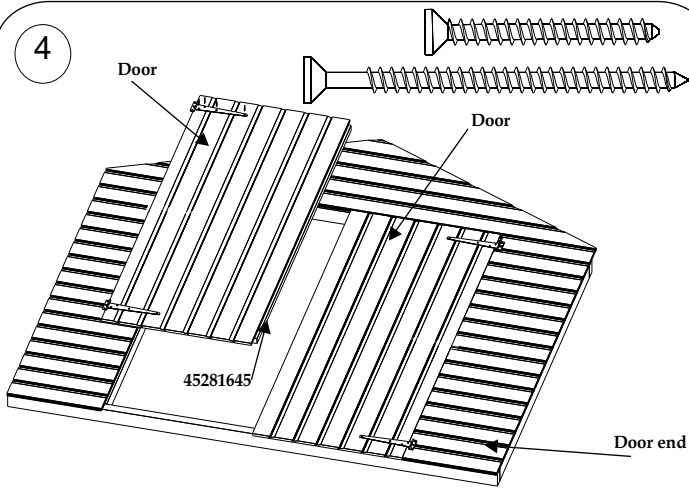

A) Fasten three hinges to each door as shown above using 30mm screws. Screws must secure into the horizontal braces on the back of each door.

B) Place door end face up on ground. Lay each door on door end of shed ensuring that both doors are square with equal gaps to left and right, and secure hinges to door end with 30mm screws.

C) Attach 45281645 (45x28x1645mm batten) to left hand door with two 50mm screws. This must be positioned so that it fits centrally within the door opening.

5

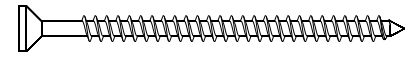

Repeat procedure outlined in steps two and three to position and secure complete front end panel and two (side window panels).

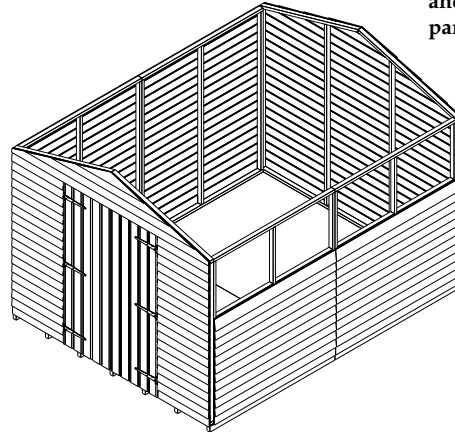

Once all panels are in place secure through each end panel into floor with three 50mm screws, and each side panel into floor with two 50mm screws. All screws must locate into floor bearers.

6

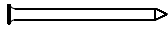

Place a 85026 (plastic "z" strip) across bottom of window opening on both (side window panels). The long edge of the z should face down on outside of workshop. Secure each strip in place with 4 panel pins.

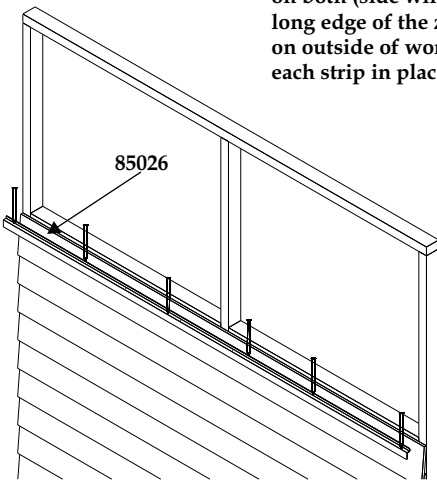

7

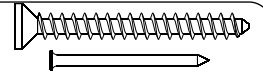

These edges must be flush.

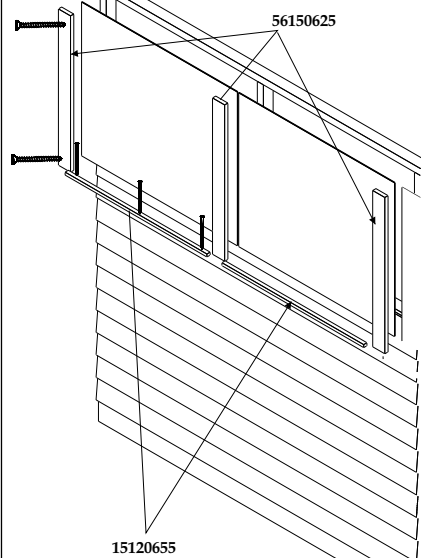

Offer a PW615720 (styrene window) up to each window opening from outside of workshop. Each PW615720 (styrene window) must be centred over window openings. Place a 56150625 (56x15x625mm cover strip) over the join of each Pw615720 (styrene window), and one at the far left and right of the row of windows, flush with the external edge of the (window panel) upright framework. Once the strips are positioned so that they hold the windows in place, secure each strip with two 30mm screws.

Place a 15120655 (15x12x655mm strip) along the bottom of each Pw615720 (styrene window) on the outside of the workshop. Strips should fit between 56120625 (56x15x625mm window cover strips). Secure each 15120655 (15x12x655mm strip) in place with three panel pins.

8

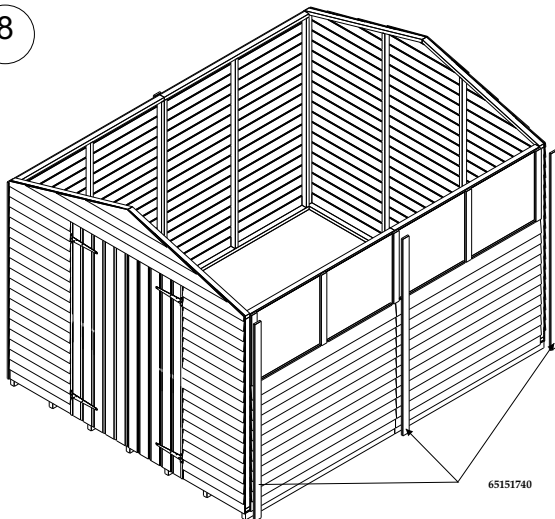

Attach a 65151740 (65x15x1740mm strip) to each corner and over the join of the panels at each side with three 30mm screws. Bottom of each 65151740 strip should be flush with bottom of cladding on each side.

9

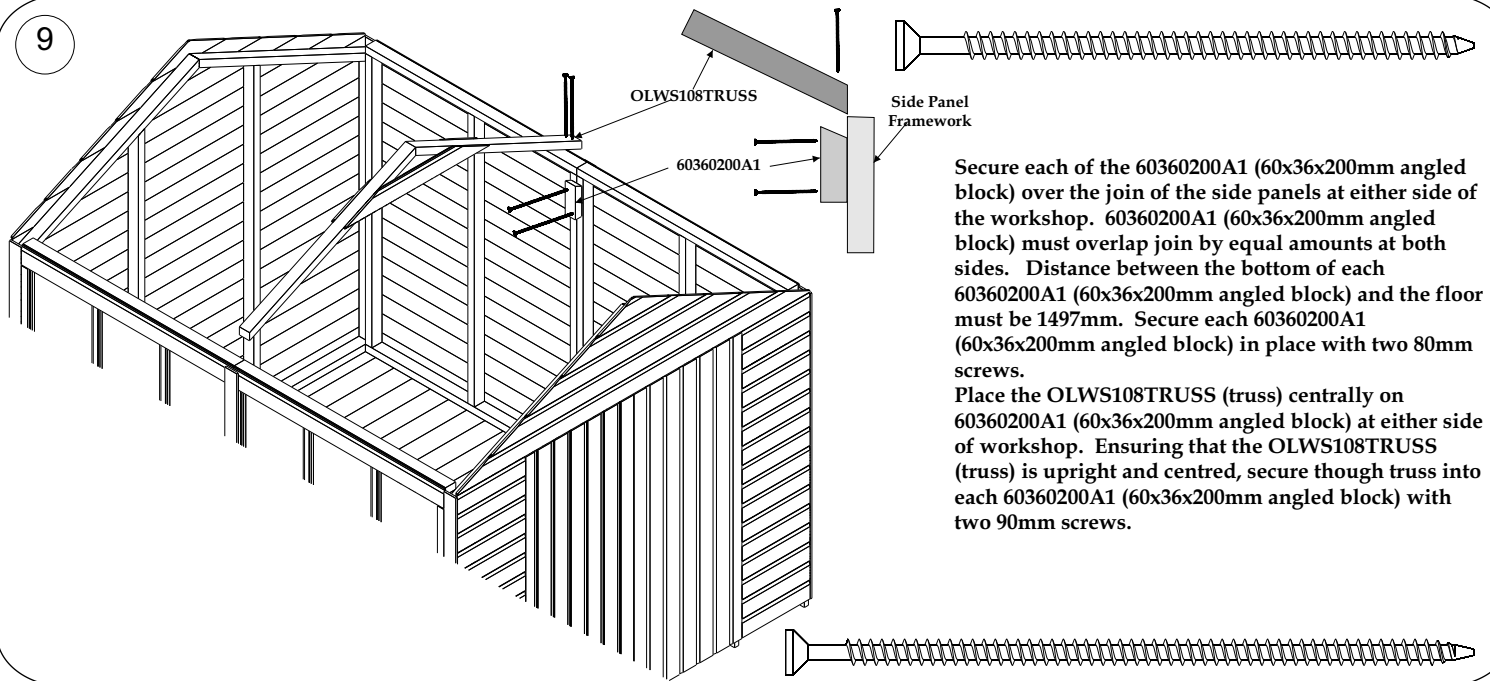

Secure each of the 60360200A1 (60x36x200mm angled block) over the join of the side panels at either side of the workshop. 60360200A1 (60x36x200mm angled block) must overlap join by equal amounts at both sides. Distance between the bottom of each 60360200A1 (60x36x200mm angled block) and the floor must be 1497mm. Secure each 60360200A1 (60x36x200mm angled block) in place with two 80mm screws.

Place the OLWS108TRUSS (truss) centrally on 60360200A1 (60x36x200mm angled block) at either side of workshop. Ensuring that the OLWS108TRUSS (truss) is upright and centred, secure through truss into each 60360200A1 (60x36x200mm angled block) with two 90mm screws.

10

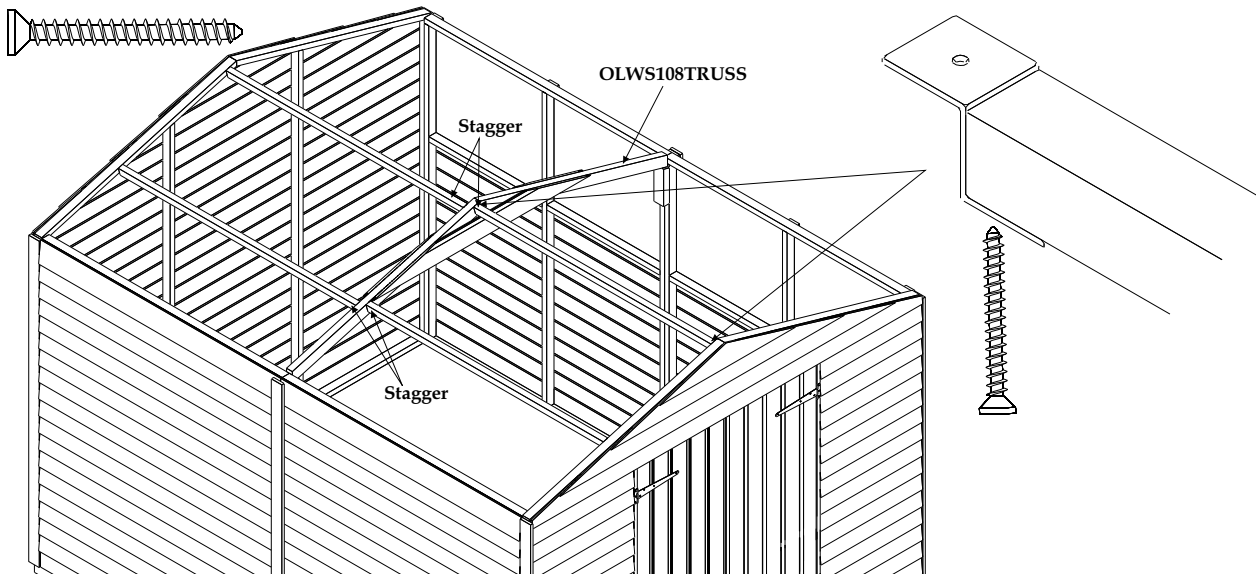

Secure one "Z" bracket to each end of each 45281462 (45x28x1462mm batten (eight battens in total)) with a 30mm screw. "Z" bracket must be secured to broad face of each 45281462 (45x28x1462mm batten) so that the top of the "Z" bracket is flush with the top of the 45281462 (45x28x1462mm batten). Place two 45281462 (45x28x1462mm batten) between the (plain end) and the OLWS108TRUSS (truss), and two battens between the (door end) and the OLWS108TRUSS (truss) on each side of the shed. "Z" brackets on each end of each 45281462 (45x28x1462mm batten) must sit on top of framework of end sections and truss. 45x28x1462mm battens should be placed approximately as shown above. It will be necessary to stagger the battens in order to allow the "Z" brackets to sit properly on truss. Secure each "Z" bracket to workshop with a 30mm screw.

11

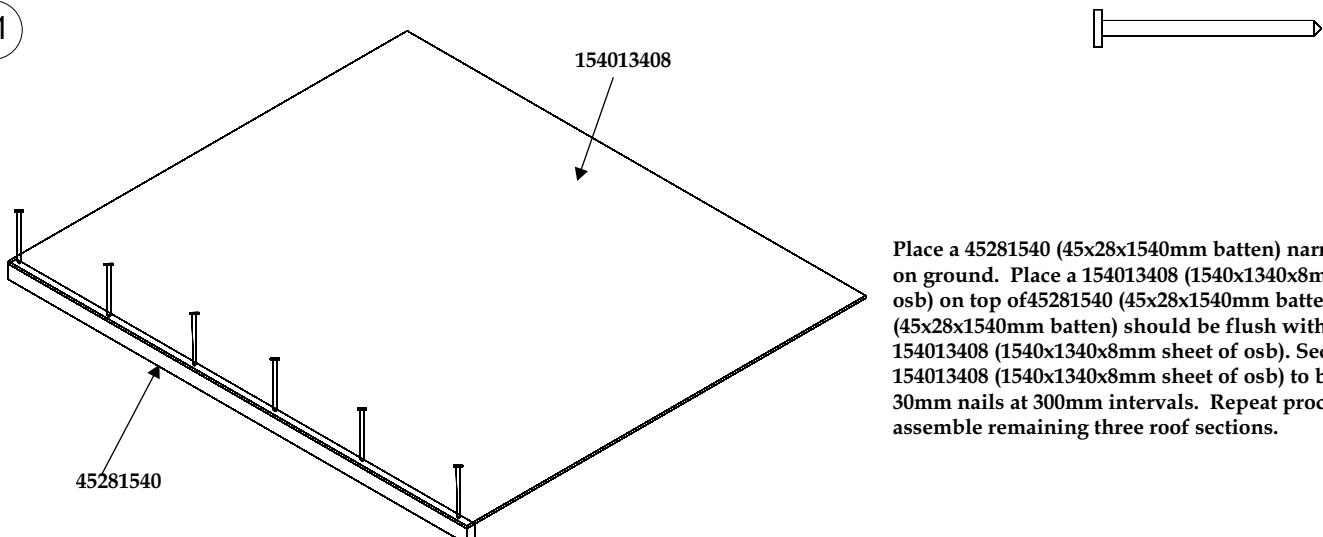

Place a 45281540 (45x28x1540mm batten) narrow side up on ground. Place a 154013408 (1540x1340x8mm sheet of osb) on top of 45281540 (45x28x1540mm batten). 45281540 (45x28x1540mm batten) should be flush with edges of 154013408 (1540x1340x8mm sheet of osb). Secure 154013408 (1540x1340x8mm sheet of osb) to batten with 30mm nails at 300mm intervals. Repeat procedure to assemble remaining three roof sections.

12

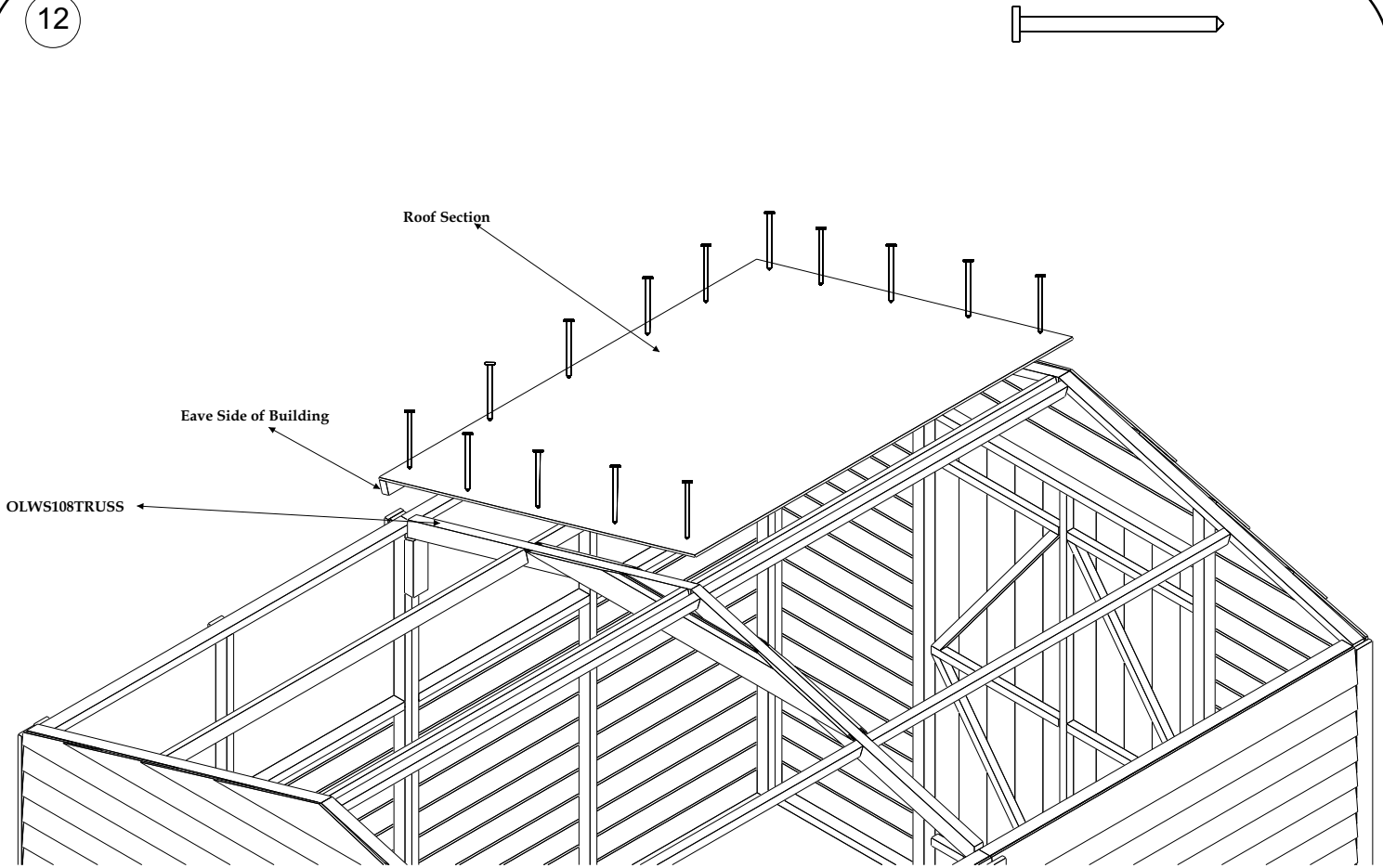

Place one of the assembled roof sections on top of the workshop. Edge of roof that has batten attached should be placed along eave of building. Roof must be positioned so that it sits on half the width of the OLWS108TRUSS (truss). Top edge of roof section should be pushed up to tip of apex. Secure roof section in place with 30mm nails at 300mm intervals along three edges. All nails must locate into framework of workshop. Repeat procedure to position and secure remaining roof sections.

13

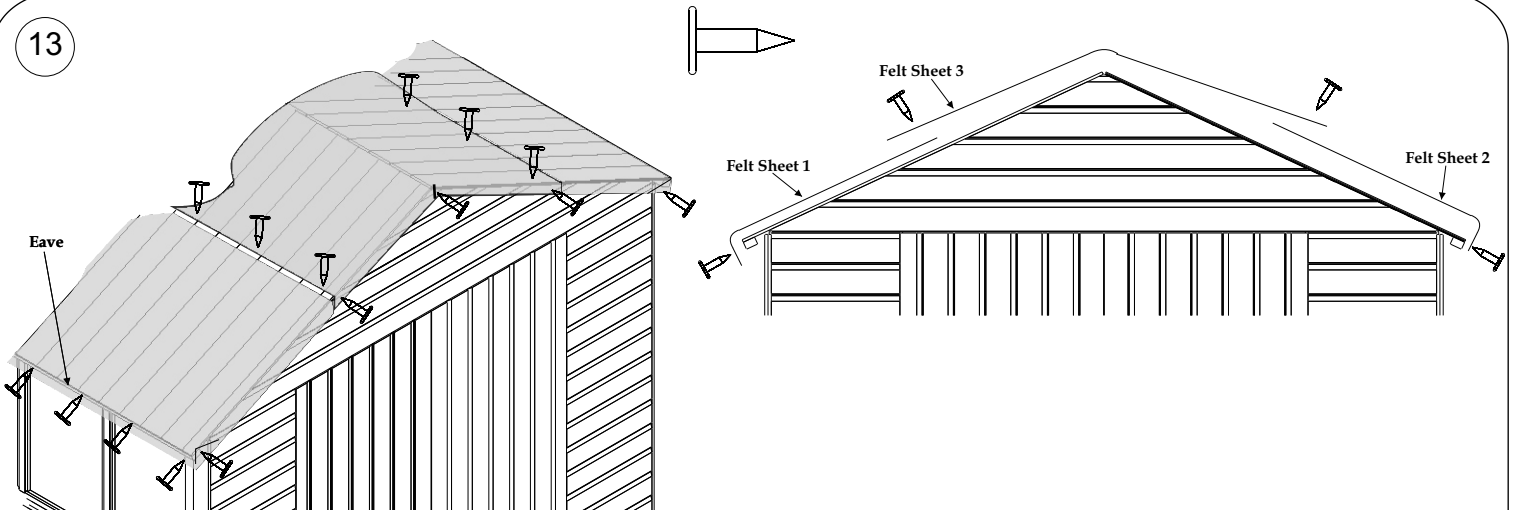

Roll first run of 85008 (green mineral felt) on to roof running from end to end of workshop. Position as shown above (Felt Sheet One), and allowing approximately 50mm overlap to front, back, and side, cut the felt to length. Secure in place along eave with felt nails placed at 150mm intervals. Cut and fold felt at corners and secure fold in place with a felt nail. Repeat procedure for felt sheet 2. Place felt sheet three as shown and secure in place with felt nails at 150mm intervals.

14

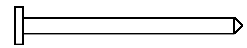
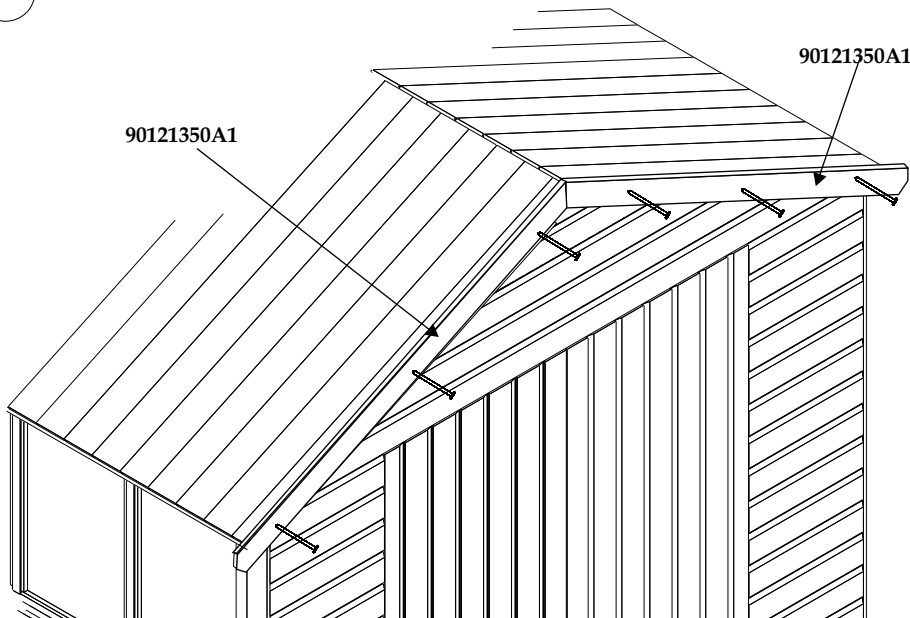

Fasten each of the 90121350A1 (90x12x1350mm angled barge boards) in place with three 30mm nails. 90121350A1 (90x12x1350mm angled barge boards) should be flush with top edge of roof and meet at the apex (highest point) of the workshop.

15

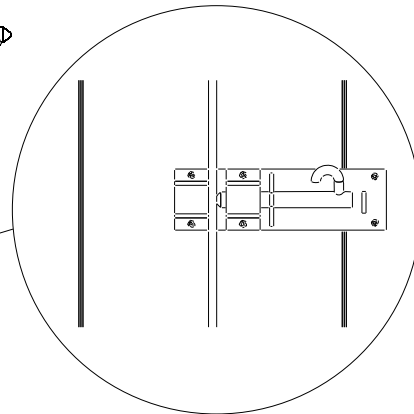
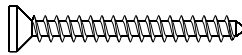
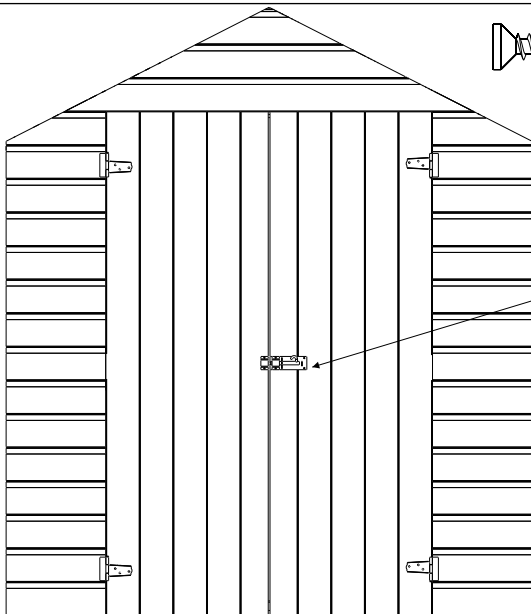

Attach pad bolt to short block on back of (1715mm door) with four 30mm screws. Attach pad bolt receiver to vertical batten on opposite door with two 30mm screws. Pad bolt and pad bolt receiver must be aligned as shown above.

16

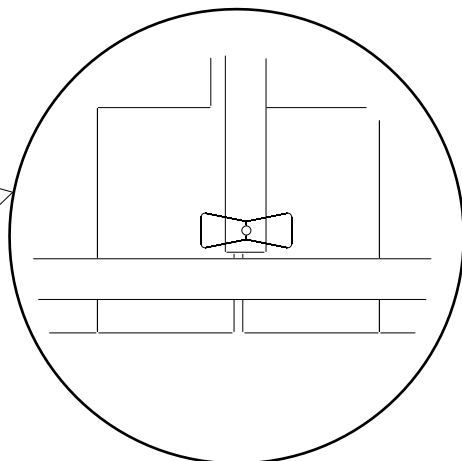
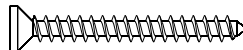
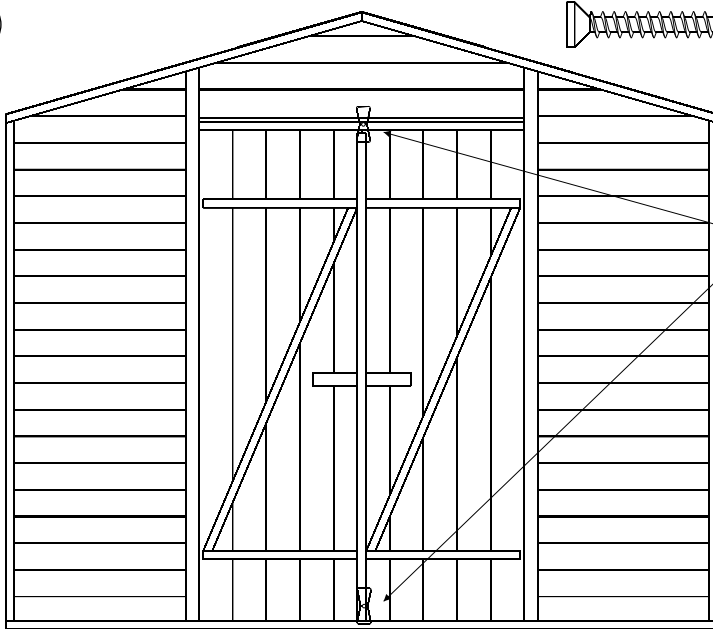

Attach a turn bottom to the top and bottom of the 45281645 (45x28x1645mm batten) with a 30mm screw. Turn buttons must be positioned so that they hold door closed against framework of door end.