

4X6 SINGLE DOOR APEX SHED - ASSEMBLY INSTRUCTIONS

SHOULD YOU REQUIRE ANY ADDITIONAL GUIDANCE WITH THE ASSEMBLY OF YOUR SHED PLEASE CONTACT OUR TECHNICAL HELP LINE ON 0844 248 9853.



IMPORTANT:
ASSEMBLY OF THIS
SHED REQUIRES TWO
PEOPLE

ISSUE 0209

"IMPORTANT. RETAIN FOR FUTURE REFERENCE :READ CAREFULLY"

Thank you for choosing this garden building manufactured by the UK's largest manufacturer of timber garden products. In order to gain the most benefit from it, please note the following:
- Exercise particular care and follow instructions whilst cutting the roofing felt. If it is cut incorrectly, additional roofing felt can be inexpensively purchased from most good DIY retailers or garden centres.

- Most buildings are pre-treated with a factory base coat for protection during storage and transit. We recommend that you treat your new building as soon as possible after assembly, using a wood preservative treatment. Apply in accordance with the manufacturers instructions.

- If there are any technical queries with the product, please contact our customer help line on 0844 248 9853 between the hours of 8.30 am and 5.00 pm Monday to Friday.

- Please ensure that you thoroughly check all component parts for quantity and quality before you commence building the product. If there are any missing parts, please contact the help line as shown immediately. The manufacturer cannot be held liable for damaged items once any part of the product has been fitted or altered in any way (e.g. Painted)

- Timber is a natural material. It will shrink and swell as a result of varying moisture content.

- Please keep all plastic bags and small parts away from children in order to reduce the risk of suffocation.

REQUIRED TOOLS : (NOT SUPPLIED)

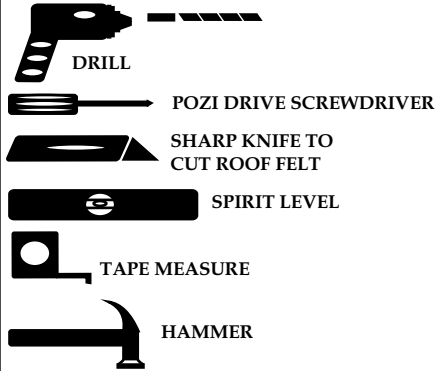

FIXING PACK CONTENTS : Fp64

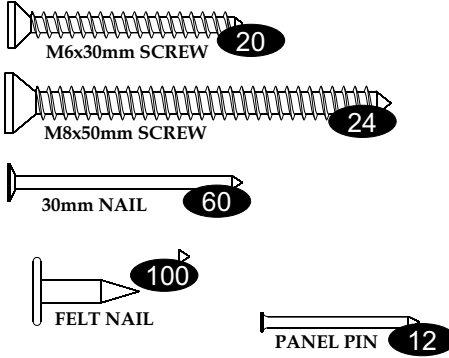

PLEASE NOTE: ALL SCREWS AND NAILS SHOWN BELOW AND IN INSTRUCTIONS ARE TO SCALE TO ASSIST IN IDENTIFICATION OF REQUIRED FIXINGS.



HASP AND STAPLE

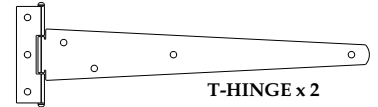

T-HINGE x 2

PARTS INCLUDED LIST

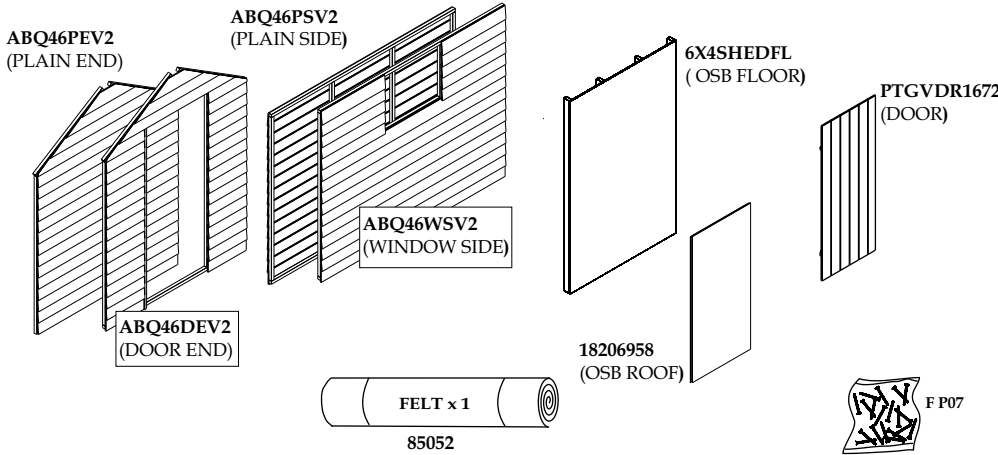

LOOSE ITEMS (ABQ46V2L)

- 45281784**
(BATTEN 45x28x1784 QTY 1)
- 28281820**
(BATTEN 28x28x1820 QTY 2)
- 15120585DTR**
(GLAZING STRIP 15x12x585DTREAT QTY 3)
- 70080730A1DTR**
(BARGE BOARD 70x8x730 A1 DTREAT QTY 4)
- 45151660DTR**
(CORNER STRIP QTY 4)
- 85009**
(PVC TRIM QTY 1)
- Pw610610**
(PVC WINDOW)

1

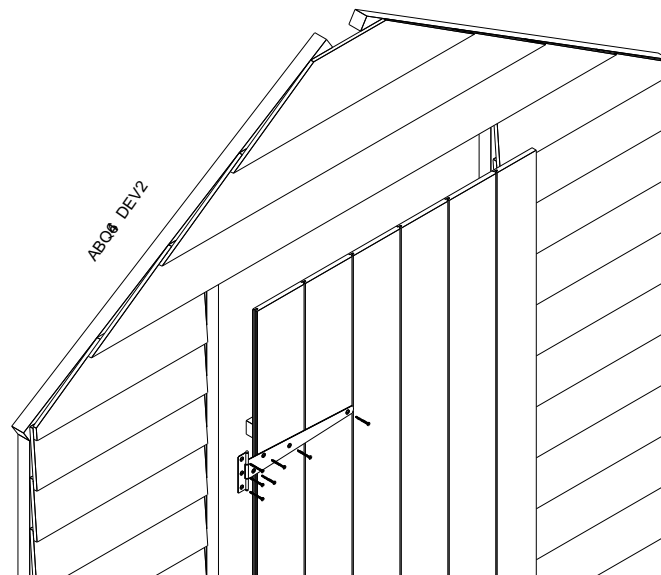

A) FASTEN EACH OF THE TWO HINGES TO THE LEFT HAND SIDE OF PTGVDR1672 (DOOR) USING 30mm SCREWS. SCREWS MUST SECURE INTO THE TWO HORIZONTAL BRACES ON THE BACK OF PTGVDR1672.

B) LAY ABQ46DEV2 (DOOR END) FACE UP ON GROUND. POSITION PTGVDR1672 (DOOR) ON ABQ46DEV2 (DOOR END) OF SHED ENSURING THAT THE PTGVDR1672 (DOOR) IS SQUARE WITH EQUAL GAPS TO LEFT AND RIGHT AND SECURE EACH HINGE TO ABQ46DEV2 (DOOR END) WITH 30mm SCREWS.

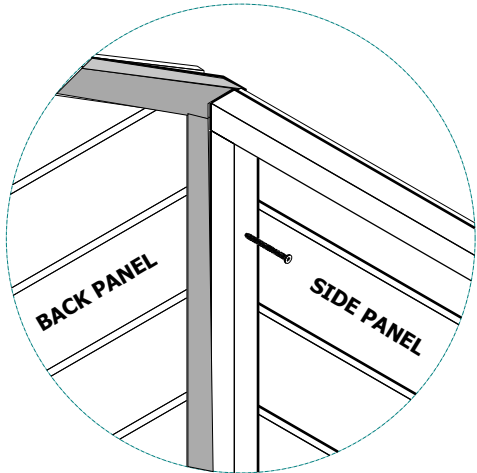
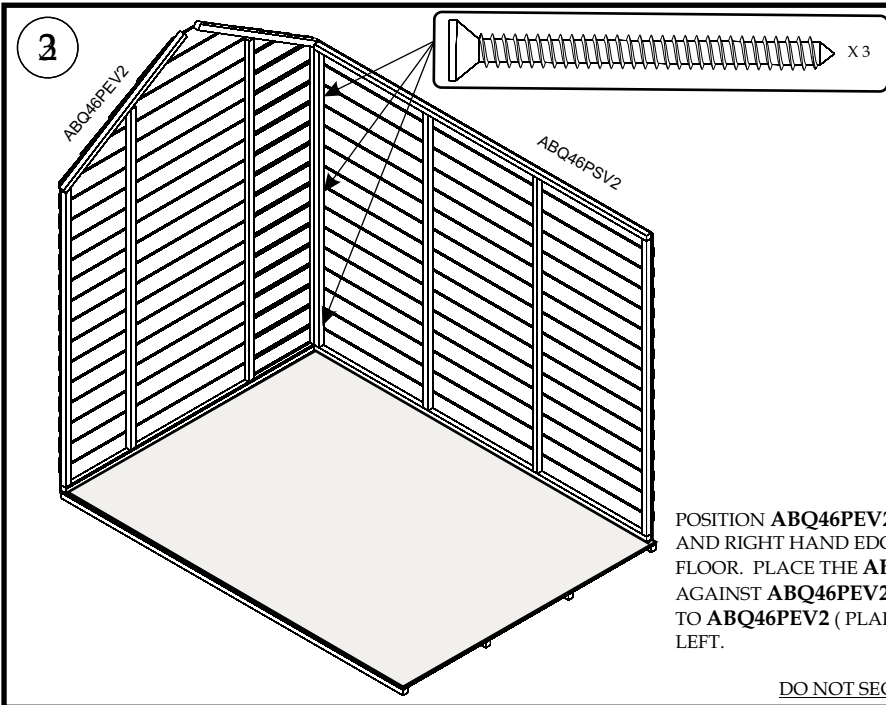

POSITION **ABQ46PEV2** (PLAIN END) OF SHED ONTO FLOOR SO THAT THE LEFT AND RIGHT HAND EDGES OF THE PANEL ARE FLUSH WITH THE EDGES OF THE FLOOR. PLACE THE **ABQ46PSV2** (PLAIN SIDE) ONTO THE FLOOR AND PLACE UP AGAINST **ABQ46PEV2V** (PLAIN END) PANEL. SECURE **ABQ46PSV2** (PLAIN SIDE) TO **ABQ46PEV2** (PLAIN END) USING 3 x 50mm SCREWS PLACED AS SHOWN TO LEFT.

DO NOT SECURE THE PANELS TO THE FLOOR AT THIS POINT.

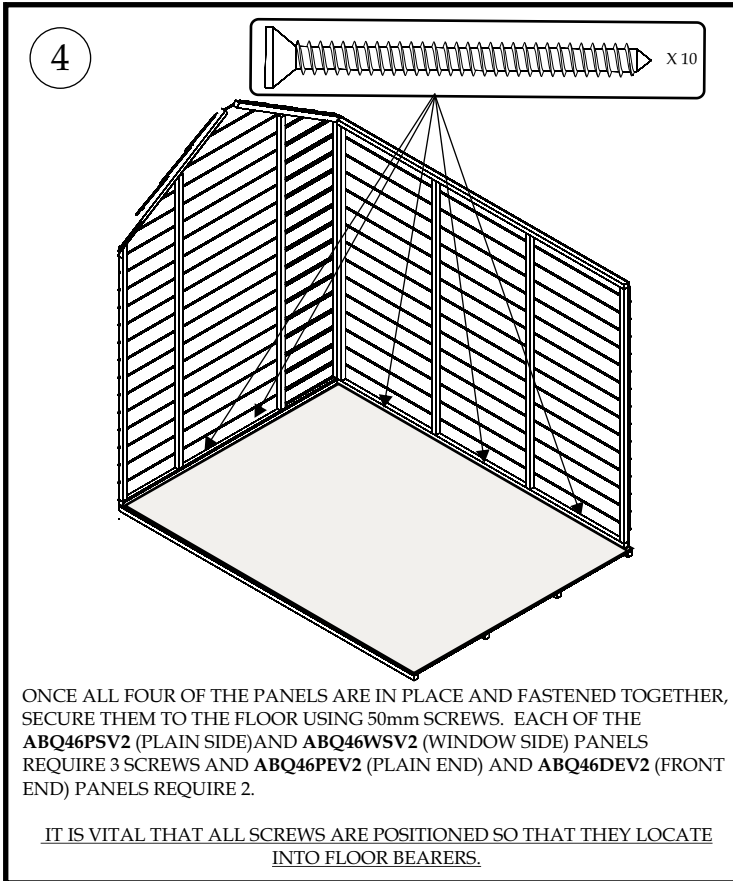
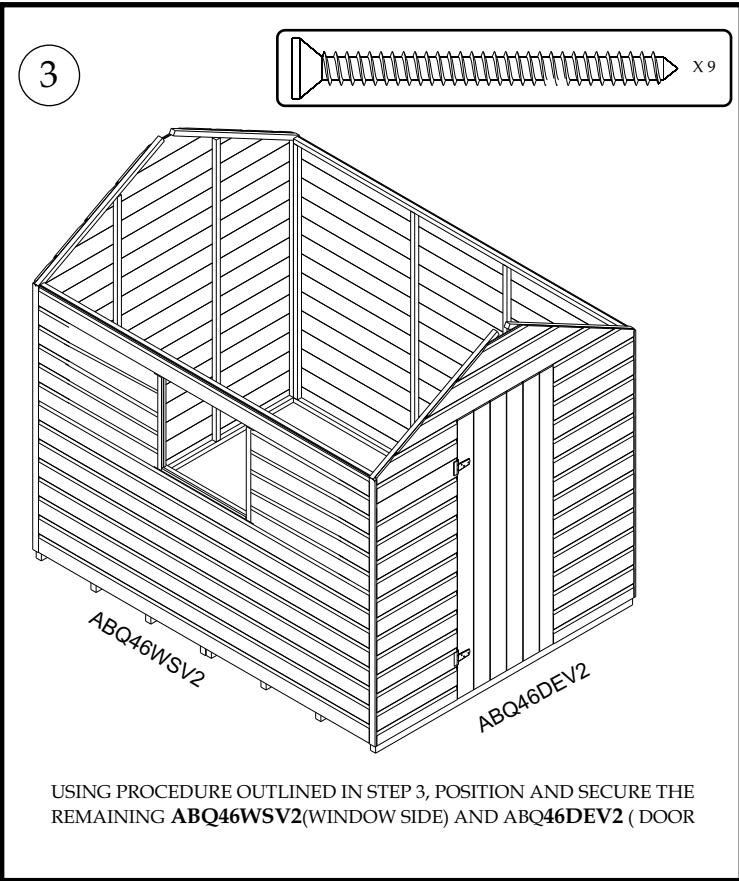

ONCE ALL FOUR OF THE PANELS ARE IN PLACE AND FASTENED TOGETHER, SECURE THEM TO THE FLOOR USING 50mm SCREWS. EACH OF THE **ABQ46PSV2** (PLAIN SIDE) AND **ABQ46WSV2** (WINDOW SIDE) PANELS REQUIRE 3 SCREWS AND **ABQ46PEV2** (PLAIN END) AND **ABQ46DEV2** (FRONT END) PANELS REQUIRE 2.

IT IS VITAL THAT ALL SCREWS ARE POSITIONED SO THAT THEY LOCATE INTO FLOOR BEARERS.

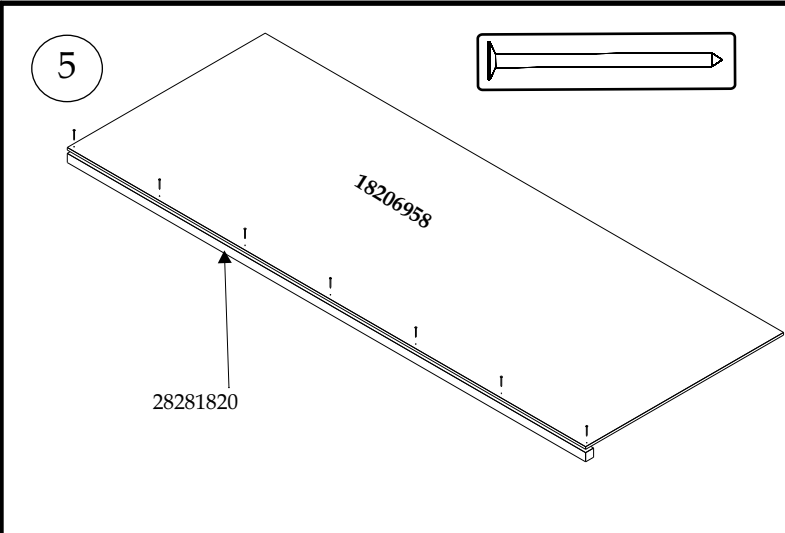

PLACE ONE **18206958** (OSB ROOF) ON TOP OF A **28281820** (BATTEN), ENSURING THAT EDGES OF **28281820** (BATTEN) AND **18206958** (OSB ROOF) ARE FLUSH, SECURE **18206958** (OSB) TO **28281820** (BATTEN) WITH 30mm NAILS PLACED AT 300mm INTERVALS. REPEAT PROCEDURE FOR SECOND ROOF SECTION.

6

50mm SCREW

45281784

PLACE **45281784** (BEARER) INTO OPENING AT THE TOP OF EACH END. PRE-DRILL A PILOT HOLE IN POSITION SHOWN ABOVE AND SECURE **45281784** (BEARER) IN PLACE AT BOTH ENDS WITH 1 x 50mm SCREW.

7

PLACED AT 300mm INTERVALS

PLACE ONE OF THE ASSEMBLED **18206958** (ROOF) SECTIONS ON TOP OF THE SHED. WHEN IN PLACE, THE **18206958** (ROOF) SECTION SHOULD OVERHANG BY EQUAL AMOUNTS AT EITHER END OF THE SHED AND SHOULD BE POSITIONED SO THAT WHEN BOTH **18206958** (ROOF) SECTIONS ARE IN PLACE THEY MEET AT A POINT. SECURE IN PLACE WITH 30mm NAILS PLACED AT 300mm INTERVALS INTO THE FRAMEWORK OF THE SIDES OF THE SHED.

8

FELT NAIL PLACED AT 150mm INTERVALS

CUT THE FELT INTO TWO EQUAL LENGTHS. PLACE THE FIRST PIECE OF FELT ON THE ROOF SO THAT IT OVERLAPS EQUAL AMOUNTS AT EITHER END OF THE SHED, AND BY APPROXIMATELY 40mm AT THE EAVE SIDE OF THE ROOF. SECURE FELT TO ROOF WITH FELT NAILS PLACED AT 150mm INTERVALS. CUT AND FOLD FELT AT CORNERS AND SECURE FOLD WITH A FELT NAIL

REPEAT PROCEDURE FOR OPPOSITE SIDE OF ROOF.

9

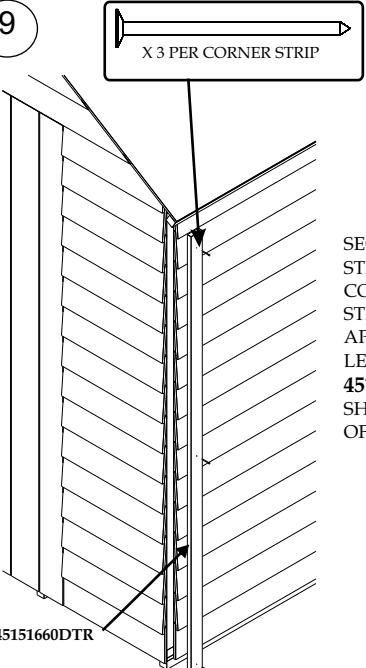

X 3 PER CORNER STRIP

45151660DTR

SECURE A **45151660DTR** (CORNER STRIP) TO EACH OF THE FOUR CORNERS WITH 3 x 30mm NAILS PER STRIP. NAILS SHOULD BE PLACED APPROXIMATELY AS SHOWN TO LEFT. THE BOTTOM OF **45151660DTR** (CORNER STRIP) SHOULD BE IN LINE WITH BOTTOM OF CLADDING ON SIDE PANELS.

10

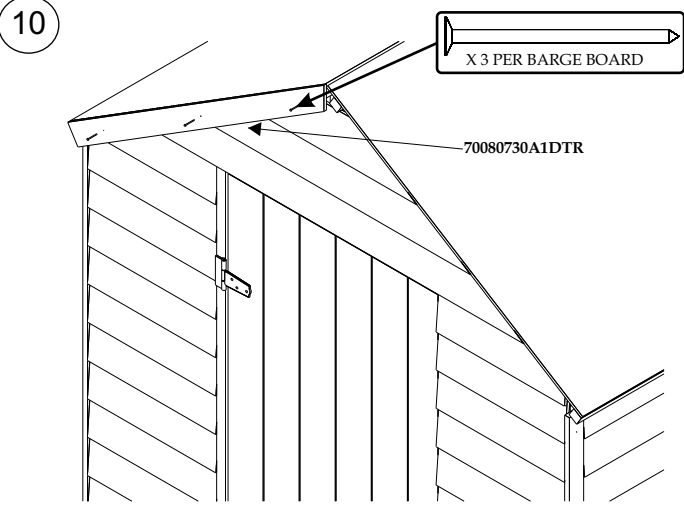

X 3 PER BARGE BOARD

70080730A1DTR

POSITION **70080730A1DTR** (BARGE BOARDS) ON BOTH ENDS OF SHED SO THAT THE TOP EDGE OF THE **70080730A1DTR** (BARGE BOARD) IS IN LINE WITH THE TOP EDGE OF THE ROOF AND THE POINT OF **70080730A1DTR** (BARGE BOARD) MEETS UP WITH THE HIGHEST POINT OF THE ROOF. SECURE EACH **70080730A1DTR** (BARGE BOARD) IN PLACE WITH 3 x 30mm NAILS PLACED AS SHOWN ABOVE. TRIM OFF ANY EXCESS FELT THAT IS SHOWING BELOW THE BARGE BOARDS.

11

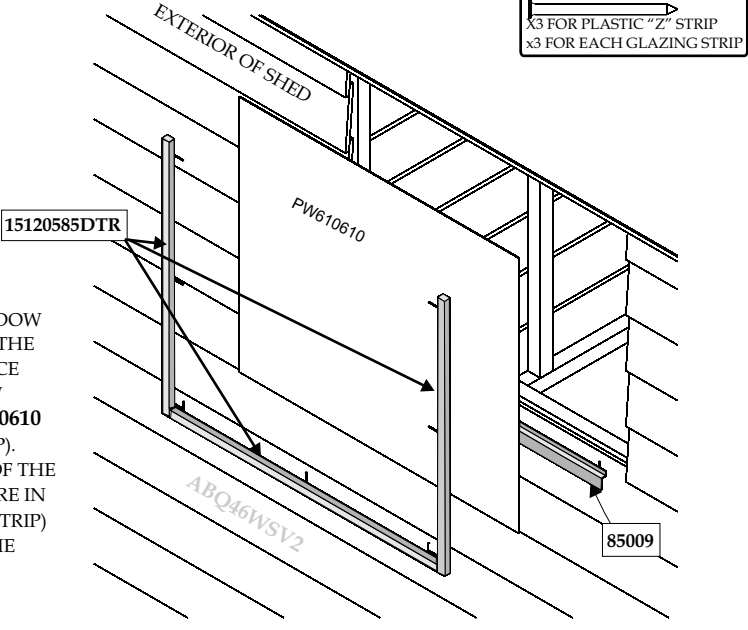

X3 FOR PLASTIC "Z" STRIP
X3 FOR EACH GLAZING STRIP

EXTERIOR OF SHED

PW610610

15120585DTR

ABQ46WSV2

85009

PLACE **85009** (PLASTIC "Z" STRIP) ACROSS BOTTOM OF THE WINDOW OPENING. THE LONG FACE OF THE Z SHOULD FACE DOWN ON THE OUTSIDE OF THE **ABQ46WSV2** WINDOW SIDE. SECURE IN PLACE WITH 3 PANEL PINS. PLACE **Pw610610** (WINDOW) INTO WINDOW OPENING FROM OUTSIDE OF SHED. THE BOTTOM OF THE **Pw610610** (WINDOW) SHOULD SIT ON TOP OF THE **85009** (PLASTIC "Z" STRIP). PLACE A **15120585DTR** (GLAZING STRIP) ALONG THE BOTTOM OF THE **Pw610610** (WINDOW) ON THE OUTSIDE OF THE SHED AND SECURE IN PLACE WITH 3 PANEL PINS. PLACE A **15120585DTR** (GLAZING STRIP) TO THE LEFT AND RIGHT OF THE **Pw610610** (WINDOW) FROM THE AND SECURE EACH IN PLACE WITH 3 PANEL PINS.

12

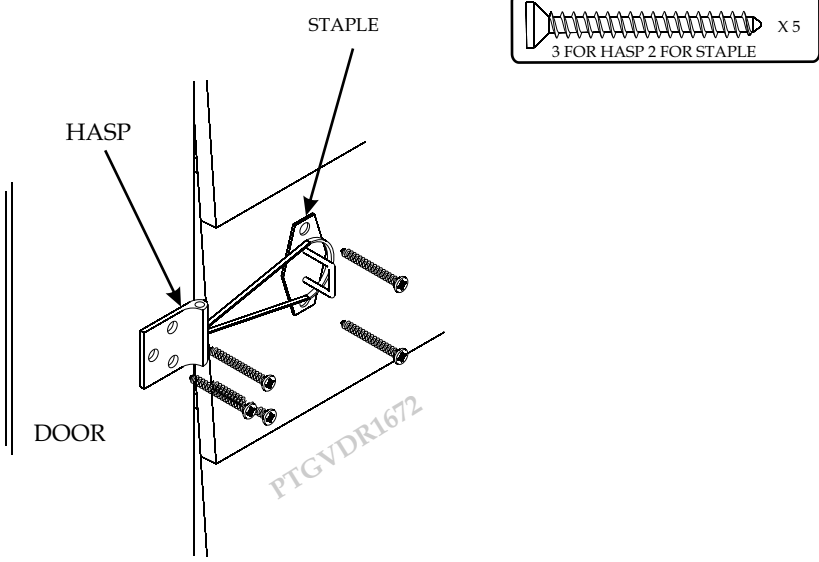

X 5
3 FOR HASP 2 FOR STAPLE

HASP

STAPLE

DOOR

PTGVDR1672

SECURE HASP TO OUTSIDE OF **PTGVDR1672** (DOOR) USING 3 30mm SCREWS. THE SCREWS MUST LOCATE INTO THE SHORT HORIZONTAL BATTEN ON THE INSIDE OF THE **PTGVDR1672** (DOOR). SECURE STAPLE TO **ABQ46DEV2** (DOOR END) OF SHED USING 2 30mm SCREWS.