

# 8 x 6 SINGLE DOOR APEX SHED - ASSEMBLY INSTRUCTIONS

SHOULD YOU REQUIRE ANY ADDITIONAL GUIDANCE WITH THE ASSEMBLY OF YOUR SHED PLEASE CONTACT OUR TECHNICAL HELP LINE ON 0844 248 9853.

"IMPORTANT, RETAIN FOR FUTURE REFERENCE: READ CAREFULLY"



IMPORTANT: ASSEMBLY OF THIS SHED REQUIRES TWO PEOPLE

ISSUE 0109

Thank you for choosing this garden building manufactured by the UK's largest manufacturer of timber garden products. In order to gain the most benefit from it, please note the following:

- Exercise particular care and follow instructions whilst cutting the roofing felt. If it is cut incorrectly, additional roofing felt can be inexpensively purchased from most good DIY retailers or garden centres.

- Most buildings are pre-treated with a factory base coat for protection during storage and transit. We recommend that you treat your new building as soon as possible after assembly, using a wood preservative treatment. Apply in accordance with the manufacturers instructions.

- If there are any technical queries with the product, please contact our customer help line on 0844 248 9853 between the hours of 8.30 am and 5.00 pm Monday to Friday.

- Please ensure that you thoroughly check all component parts for quantity and quality before you commence building the product. If there are any missing parts, please contact the help line as shown immediately. The manufacturer cannot be held liable for damaged items once any part of the product has been fitted or altered in any way (e.g. Painted)

- Timber is a natural material. It will shrink and swell as a result of varying moisture content.

- Please keep all plastic bags and small parts away from children in order to reduce the risk of suffocation.

## REQUIRED TOOLS : (NOT SUPPLIED)

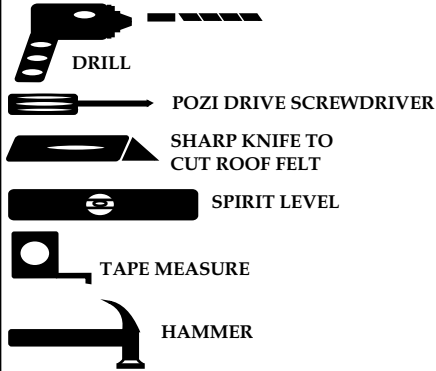

## FIXING PACK CONTENTS :

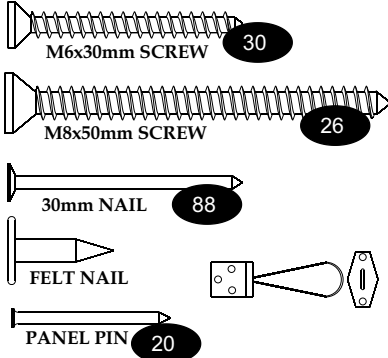

PLEASE NOTE: ALL SCREWS AND NAILS SHOWN BELOW AND IN INSTRUCTIONS ARE TO SCALE TO ASSIST IN IDENTIFICATION OF REQUIRED FIXINGS.

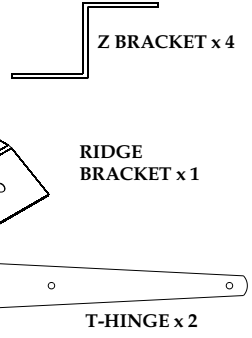

## PARTS INCLUDED LIST

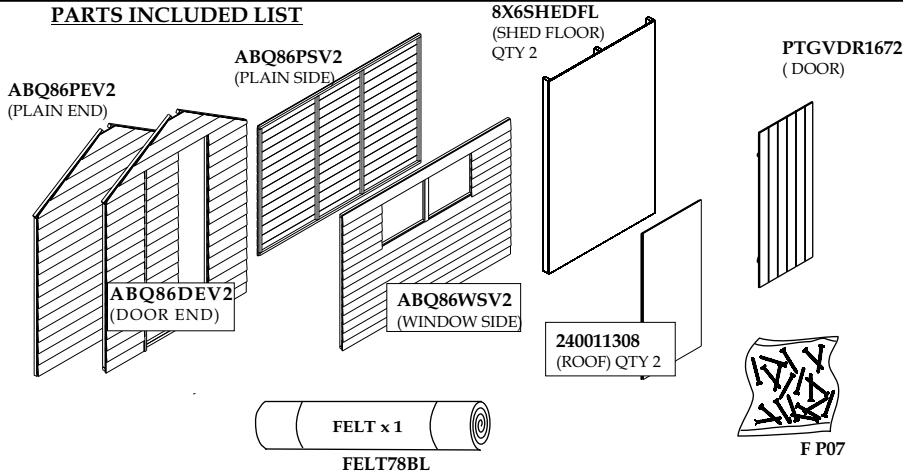

## LOOSE ITEM (ABQ86V2L)

**15120585 DTR**  
( GLAZING STRIP 15x12x585  
DTREAT QTY 6)

**28282294**  
(BATTEN 28x28x2294mm QTY 2)

**28282400**  
(BATTEN 28x28x2400mm QTY 4)

**58281784PTR**  
(BATTEN 58x28x1784mm  
PTREAT QTY 4)

**70081150A1DTR**  
(BARGE BOARD 70x8x1150mm  
A1 DTREAT QTY 4)

**45151600DTR**  
(CORNER STRIP 45X15x1600mm  
DTREAT QTY4)

**Pw610520**  
(STYRENE WINDOW QTY 2)

**85009**  
(PVC TRIM QTY 2)

1

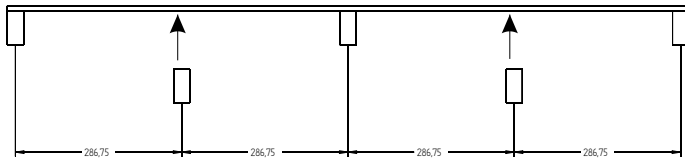
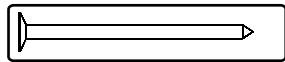

ABOVE ILLUSTRATION PROVIDES MEASUREMENTS FOR PLACEMENT OF **58281784PTR** ( BEARERS). SECURE EACH **58281784PTR** (BEARER) IN PLACE WITH 30mm NAILS AT 300mm INTERVALS. BEARERS MARKED WITH ARROWS REQUIRE ATTACHMENT.

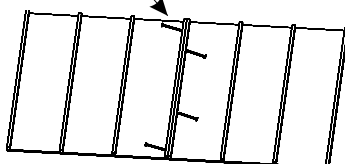
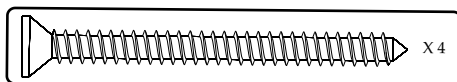

FOLLOW PROCEDURE ABOVE FOR ASSEMBLING EACH **8X6SHEDFL** (FLOOR) SECTION AND THEN FASTEN THE SECTIONS TOGETHER WITH 4 x 50mm SCREWS AS SHOWN TO RIGHT.

2

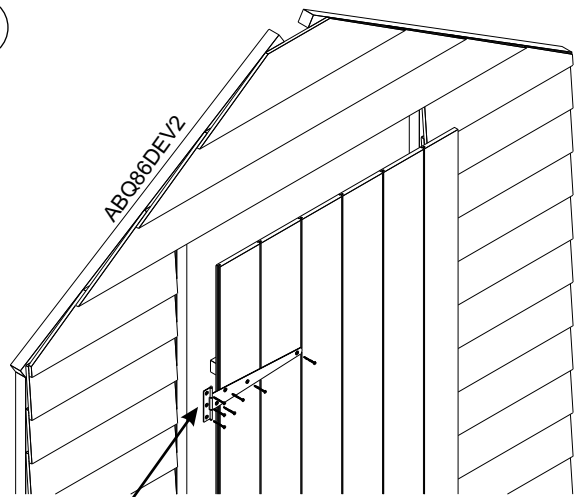

A) FASTEN EACH OF THE TWO HINGES TO THE LEFT HAND SIDE OF THE **PTGVDR1672** ( DOOR) USING 30mm SCREWS. SCREWS MUST SECURE INTO THE TWO HORIZONTAL BRACES ON THE BACK OF THE **PTGVDR1672** ( DOOR).

B) LAY **ABQ86DEV2** (DOOR END) FACE UP ON GROUND. POSITION **PTGVDR1672** DOOR ON **ABQ86DEV2** (DOOR END) OF SHED ENSURING THAT THE **PTGVDR1672** (DOOR) IS SQUARE WITH EQUAL GAPS TO LEFT AND RIGHT AND SECURE EACH HINGE TO **ABQ86DEV2** (DOOR END) WITH 30mm SCREWS.



ABQ86PEV2

7

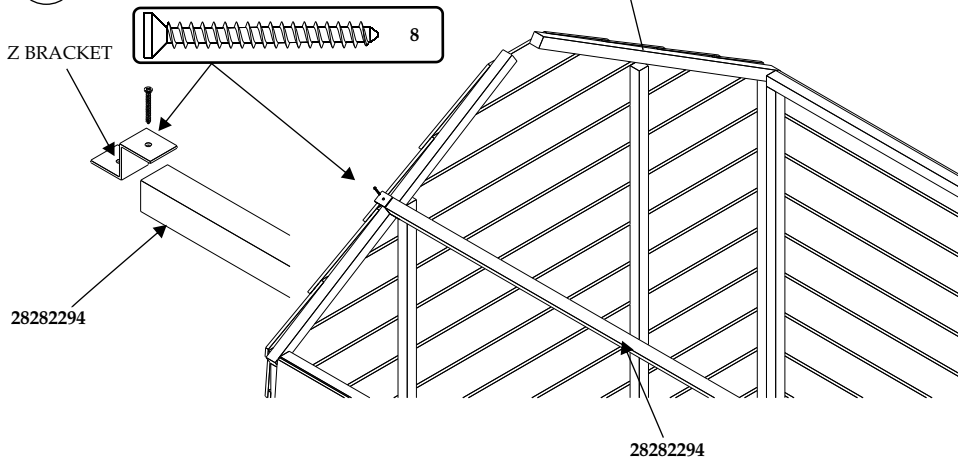

SECURE 1 "Z" BRACKET TO BOTH ENDS OF A **28282294** (BATTEN) WITH A 30mm SCREW. PLACE **28282294** (BATTEN) WITH "Z" BRACKETS BETWEEN ENDS OF SHED SO THAT THE "Z" BRACKET SITS ON TOP OF THE END SECTION FRAMEWORK AND UNDER THE ROOF BATTEN. THE **28282294** (BATTEN) WITH "Z" BRACKETS SHOULD BE PLACED APPROXIMATELY HALF WAY BETWEEN THE SIDE AND THE MIDDLE OF THE SHED AND THEN SECURED AT BOTH ENDS WITH A 30mm SCREW. REPEAT PROCEDURE WITH SECOND **28282294** (BATTEN) AND REMAINING 2 "Z" BRACKETS.

8

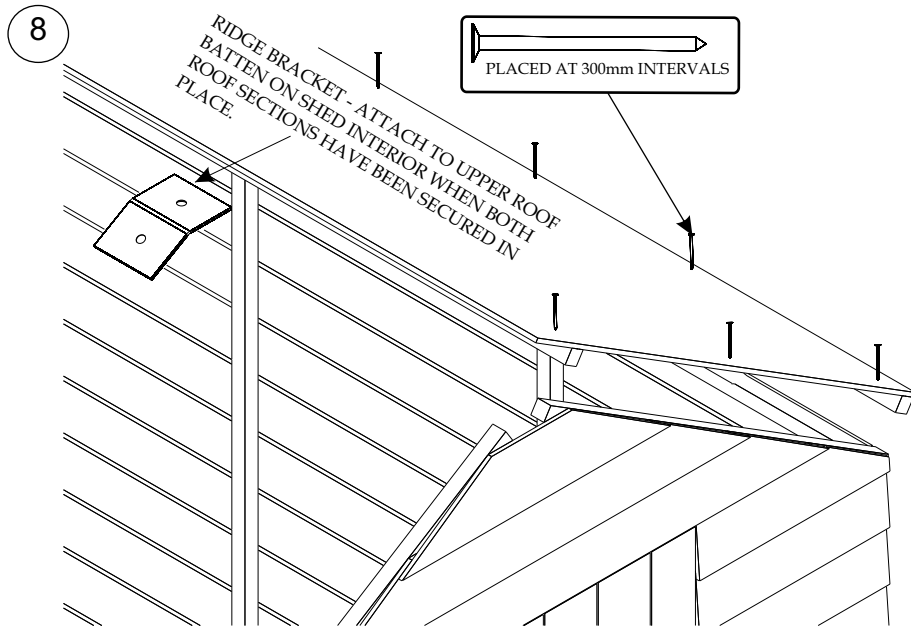

PLACE ONE OF THE ASSEMBLED **240011308** (ROOF) SECTIONS ON TOP OF THE SHED. WHEN IN PLACE, THE **240011308** (ROOF) SECTION SHOULD OVERHANG BY EQUAL AMOUNTS AT EITHER END OF THE SHED AND SHOULD BE POSITIONED SO THAT WHEN BOTH **240011308** (ROOF) SECTIONS ARE IN PLACE THEY MEET AT A POINT. SECURE IN PLACE WITH 30mm NAILS PLACED AT 300mm INTERVALS INTO THE FRAMEWORK OF THE SIDES OF THE SHED.

**REPEAT THIS PROCEDURE FOR THE REMAINING ROOF SECTION.**

ONCE BOTH THE **240011308** (ROOF) SECTIONS ARE IN PLACE. SECURE THEM TOGETHER ON THE INSIDE, USING THE RIDGE BRACKET PROVIDED, AT THE HIGHEST POINT. FIX THE RIDGE BRACKET TO EACH OF THE **240011308** (ROOF) ON THE HIGHEST **28282294** (BATTENS) USING 2x30mm SCREWS.

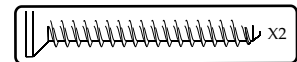

9

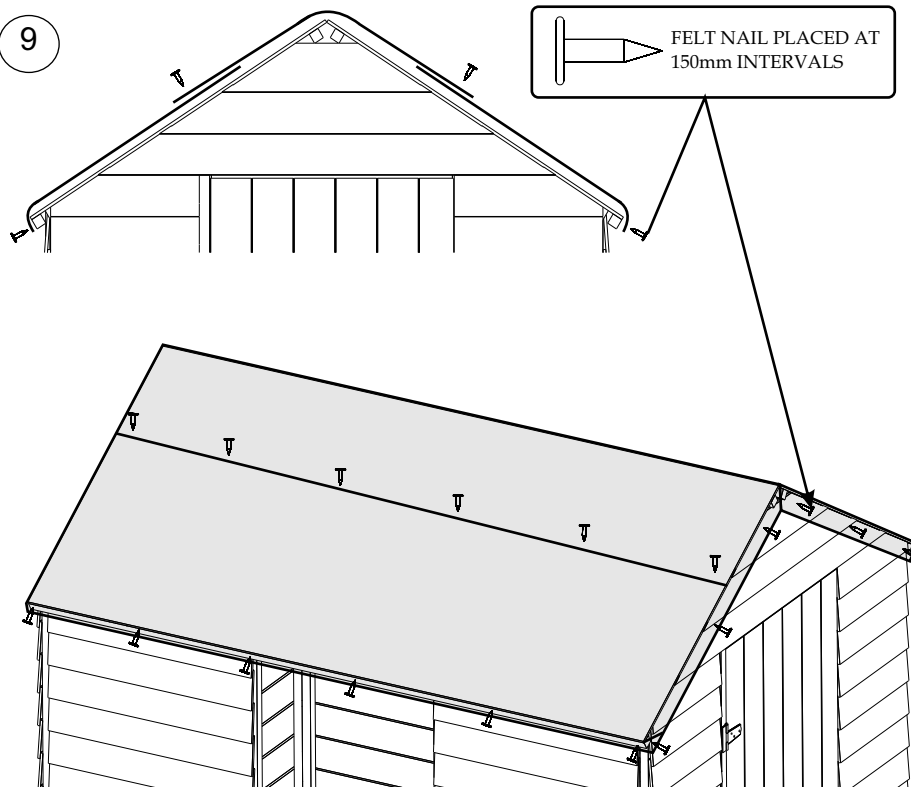

OPEN ROOFING FELT AND ROLL OUT FLAT ON GROUND. CUT THE FELT INTO THREE EQUAL LENGTHS. PLACE THE FIRST PIECE OF FELT ON THE ROOF SO THAT IT OVERLAPS EQUAL AMOUNTS AT EITHER END OF THE SHED, AND BY APPROXIMATELY 40mm AT THE EAVE (LOWER) SIDE OF THE ROOF. SECURE FELT TO ROOF WITH FELT NAILS PLACED AT 150mm INTERVALS. CUT AND FOLD FELT AT CORNERS AND SECURE FOLD WITH A FELT NAIL. REPEAT PROCEDURE FOR OPPOSITE SIDE OF ROOF. PLACE THE THIRD PIECE OF FELT ON THE APEX OF THE ROOF SO THAT IT OVERLAPS EQUALLY AT EITHER END AND EITHER SIDE OF THE ROOF. SECURE FELT TO ROOF WITH FELT NAILS PLACED AT 150mm INTERVALS ALONG EITHER SIDE.

10

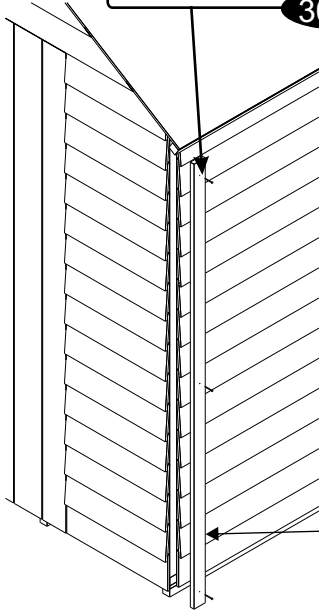
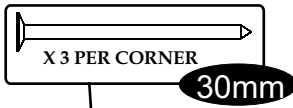

SECURE A **45151600DTR** (CORNER STRIP) TO EACH OF THE FOUR CORNERS WITH 3 x 30mm NAILS PER STRIP. NAILS SHOULD BE PLACED APPROXIMATELY AS SHOWN. THE BOTTOM OF **45121600DTR** (CORNER) STRIP SHOULD BE IN LINE WITH BOTTOM OF CLADDING ON SIDE PANELS.

45121600DTR

11

70081150A1DTR

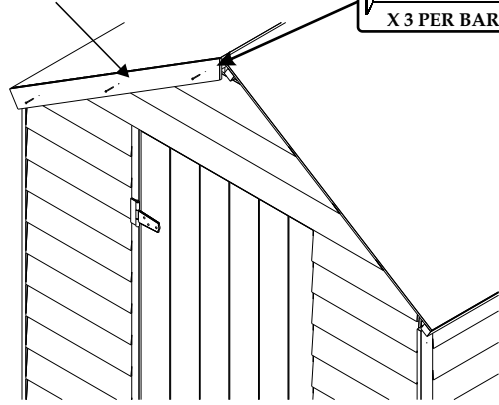
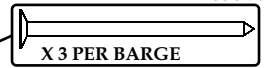

POSITION **70081150A1DTR** (BARGE BOARDS) ON BOTH ENDS OF SHED SO THAT THE TOP EDGE IS IN LINE WITH THE TOP EDGE OF THE ROOF AND THE POINT OF THE **70081150A1DTR** (BARGE BOARD) MEETS UP WITH THE HIGHEST POINT OF THE ROOF. SECURE EACH **70081150A1DTR** (BARGE BOARD) IN PLACE WITH 3 x 30mm NAILS PLACED AS SHOWN ABOVE. TRIM OFF ANY EXCESS FELT THAT IS SHOWING BELOW THE **70081150A1DTR** (BARGE BOARDS).

12

DETACH **50120510DTR** (COVER STRIPS) FROM **ABQ86WSV2** (WINDOW SIDE)

PLACE PLASTIC "Z" STRIP ACROSS BOTTOM OF WINDOW OPENING. THE LONG EDGE OF THE Z SHOULD FACE DOWN ON OUTSIDE OF SHED. SECURE IN PLACE WITH 3 PANEL PINS. PLACE **Pw610520** (WINDOWS) INTO WINDOW OPENING FROM OUTSIDE OF SHED. PLACE THE ONE OF THE **15120585DTR** (GLAZING STRIPS) ALONG THE BOTTOM OF THE WINDOW ON THE OUTSIDE OF THE SHED, MAKING SURE IT IS FLUSH AGAINST THE CLADDING, AND SECURE IN PLACE WITH 3 PANEL PINS. (DO THIS FOR BOTH WINDOWS). PLACE **50120510DTR** (COVER STRIP) AGAINST THE CENTRAL WINDOW BEAM AND OVER THE **Pw610520** (PVC WINDOWS) SECURING IN PLACE WITH 2 PANEL PINS, TAKING CARE NOT TO HIT ANY OF THE **Pw610520** (PVC WINDOWS).

PLACE THE REMAINING **15120585DTR** (GLAZING STRIPS) TO THE LEFT AND RIGHT OF **Pw610520** (WINDOWS) ON THE OUTSIDE OF THE SHED AND SECURE EACH IN PLACE WITH 3 PANEL PINS.

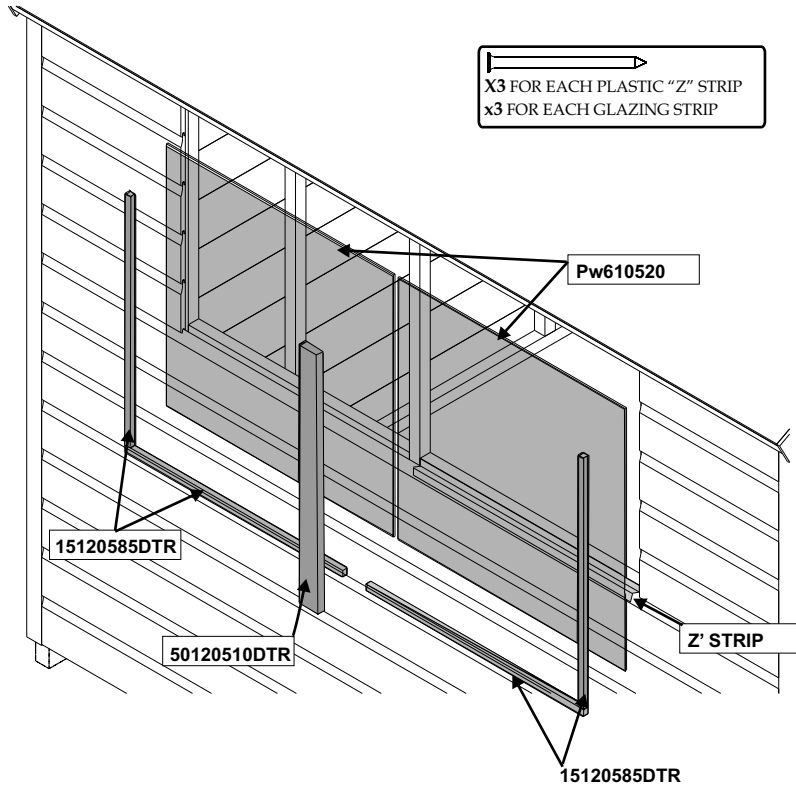

Pw610520

15120585DTR

50120510DTR

Z' STRIP

15120585DTR

13

SECURE HASP TO OUTSIDE OF **PTGVDR1672** (DOOR) USING 3 30mm SCREWS. THE SCREWS MUST LOCATE INTO THE SHORT HORIZONTAL BATTEN ON THE INSIDE OF THE **PTGVDR1672** (DOOR). SECURE STAPLE TO **ABQ86DEV2** (DOOR END) OF SHED USING 2 30mm SCREWS.

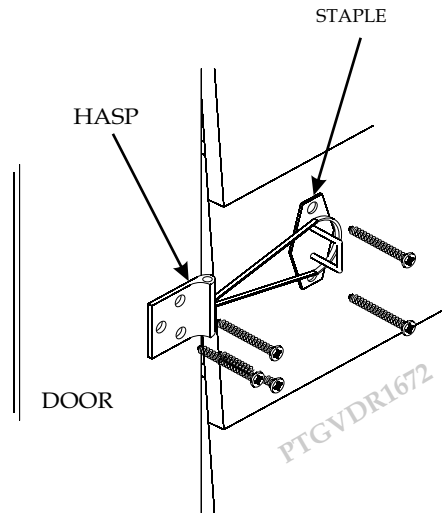

STAPLE

HASP

DOOR

PTGVDR1672

